

F5 nipple

Material / วัสดุ | SS, SUS

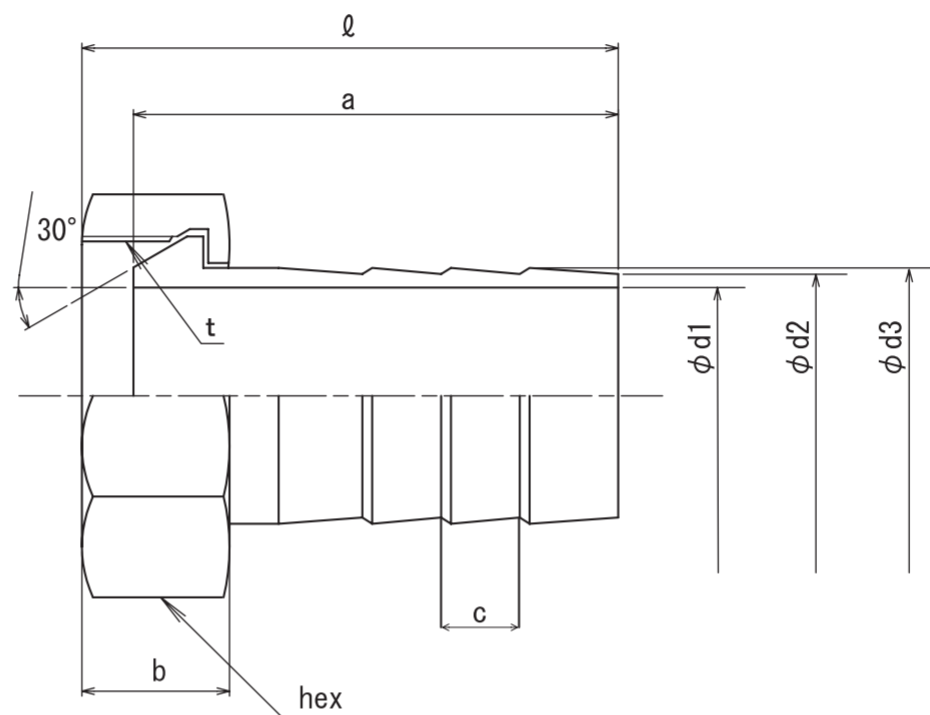

(mm)

Nominal diameter	t	a	b	d1	d3	ℓ	hex
12	G 1/2	57 (49)	21	9.0	14.0	65 (57)	27
19	G 3/4	69 (61)	24	16.0 (15.0)	20.5	77 (69)	32
25	G 1	75	28	21.0	27.0	86	38
32	G 1 1/4	85	31	28.0	34.0	96	50
38	G 1 1/2	96		33.0	40.3	107	60
50	G 2	99	33	44.5	52.0	112	70
65	G 2 1/2	125 (108)	40	56.0	65.0	139 (131)	90
75	G 3	141 (124)	42	69.0	77.5	156 (148)	100
100	G 4	188	55	90.0	102.0	208	130

Note 1 Screw notation G is Parallel Pipe Thread (PF).

Note 2 The value of () is SUS

หมายเหตุ 1 สัญลักษณ์สกรู G เป็นเกลียวท่อแบบเพปอร์ (PF)

หมายเหตุ 2 ค่าใน () คือ SUS